

# GeoMax Zoom25/50 Series



**GE**  **MAX**

**Quick Guide**  
Version 1.0



|                          |     |
|--------------------------|-----|
| Quick Guide.....         | 5   |
| Quick Guide.....         | 21  |
| Guía Rápida.....         | 37  |
| Guide abrégé.....        | 53  |
| Guida rapida.....        | 69  |
| Guia Rápido.....         | 85  |
| Краткое руководство..... | 101 |

EN

DE

ES

FR

IT

PT-BR

RU



# GeoMax Zoom25/50 Series



**GE**  **MAX**

**Quick Guide**  
Version 1.0  
English

# 1 Important Information about your Instrument

---



Read and follow the User Manual on the accompanying USB stick before using the product.

---



Keep for future reference!

---

## Intended use

- Measuring horizontal and vertical angles.
  - Measuring distances.
  - Visualising the aiming direction and vertical axis.
- 

## Laser products

The instruments contain the following laser products:

| Laser product                                | Laser class |
|--|-------------|
| EDM (Electronic Distance Measurement) module |             |
| • measurements with reflectors               | Class 1     |
| • measurements without reflectors*           | Class 3R    |
| Red laser pointer*                           | Class 3R    |
| Laser plummet                                | Class 2     |

\* optional laser product

- The classification for the EDM, red laser pointer and laser plummet is in accordance with IEC 60825-1 (2014-05).

 **CAUTION****3R laser products**

From a safety perspective, class 3R laser products should be treated as potentially hazardous.

**Precautions:**

- ▶ 1. Prevent direct eye exposure to the beam.
  - ▶ 2. Do not direct the beam at other people.
- 

 **CAUTION****Class 2 laser products**

From a safety perspective, class 2 laser products are not inherently safe for the eyes.

**Precautions:**

- ▶ 1. Avoid staring into the beam or viewing it through optical instruments.
  - ▶ 2. Avoid pointing the beam at other people or at animals.
-



## Locations of laser apertures

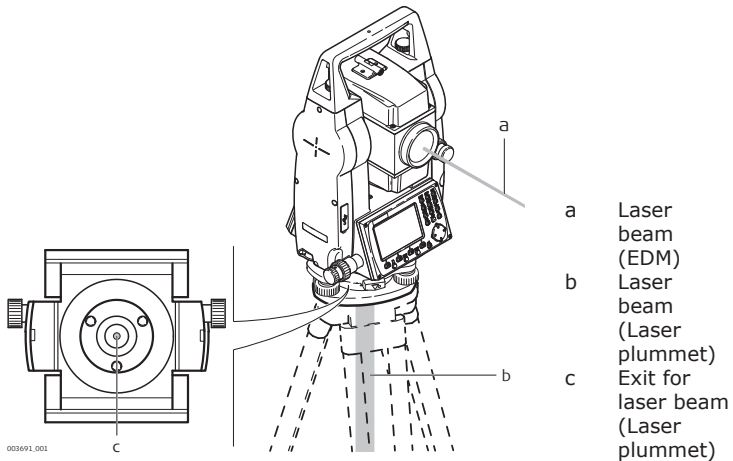



The product must not be disposed with household waste.

---

### Conformity to national regulations

- FCC Part 15 (applicable in US).
  - Hereby, GeoMax AG, declares that the radio equipment type Zoom25/Zoom50 is in compliance with the Directive 2014/53/EU and other applicable European Directives. The full text of the EU declaration of conformity may be consulted at <http://www.geomax-positioning.com/Downloads.htm>.
- 
 Class 1 equipment according European Directive 2014/53/EU (RED) can be placed on the market and be put into service without restrictions in any EEA Member state.
- The conformity for countries with other national regulations not covered by the FCC part 15 or European directive 2014/53/EU has to be approved prior to use and operation.

## Dangerous Goods Regulations

The products of GeoMax are powered by Lithium batteries.

Lithium batteries can be dangerous under certain conditions and can pose a safety hazard. In certain conditions, Lithium batteries can overheat and ignite.



When carrying or shipping your GeoMax product with Lithium batteries onboard a commercial aircraft, you must do so in accordance with the **IATA Dangerous Goods Regulations**.



GeoMax has developed **Guidelines** on “How to carry GeoMax products” and “How to ship GeoMax products” with Lithium batteries. Before any transportation of a GeoMax product, we ask you to consult these guidelines on our web page (<http://www.geomax-positioning.com/dgr>) to ensure that you are in accordance with the IATA Dangerous Goods Regulations and that the GeoMax products can be transported correctly.



Damaged or defective batteries are prohibited from being carried or transported onboard any aircraft. Therefore, ensure that the condition of any battery is safe for transportation.

## 2 Instrument Components

### Instrument components part 1 of 2

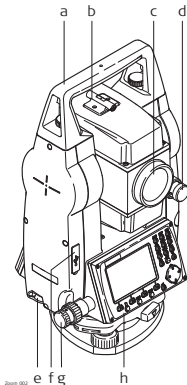

- a Detachable carrying handle
- b Optical sight
- c Objective with integrated Electronic Distance Measurement (EDM). Exit for EDM laser beam
- d Vertical drive
- e Interface RS232/USB
- f USB host port
- g Horizontal drive
- h Second keyboard\*

\* Optional

## Instrument components part 2 of 2

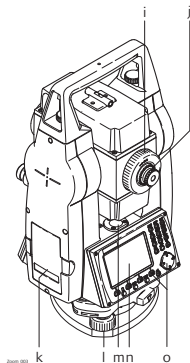

- i Focusing telescope image
- j Eyepiece; focusing graticule
- k Battery cover
- l Foot screw
- m Circular level
- n Display
- o Keyboard

## Keyboard



The keyboard layout may differ depending on the instrument model.



- a Alphanumeric keypad
- b Navigation key
- c **ENTER** key
- d Function keys **F1** to **F4**
- e **ESC** key
- f **FNC** key
- g **PAGE** key

### 3

## Technical Data

### Environmental specifications

#### Temperature

| Operating temperature [°C] | Storage temperature [°C] |
|----------------------------|--------------------------|
| -20 to +50                 | -40 to +70               |

#### Protection against water, dust and sand

IP55 (IEC 60529)

#### Humidity

Max 95 % non condensing.

The effects of condensation are to be effectively counteracted by periodically drying out the instrument.

## 4

## Care and Transport

---

### Care and transport

- Carry the product in its original container or carry the tripod with its legs splayed across your shoulder, to protect the product against shock and vibration.
  - Periodically carry out test measurements and perform the field adjustments indicated in the User Manual, particularly after the product has been dropped, stored for long periods or transported.
-



# 5 Operation

## Turning on and off the instrument

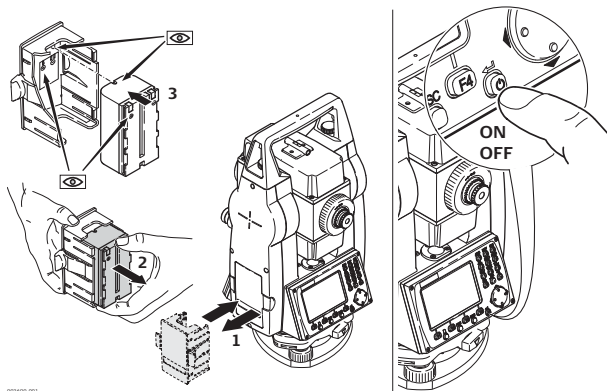



The battery must be charged before using it for the first time.

---





## **866471-1.0.0en**

Original text (866471-1.0.0en)

© 2017 GeoMax AG, Widnau, Switzerland



**GeoMax AG**  
[www.geomax-positioning.com](http://www.geomax-positioning.com)

# GeoMax Zoom25/50 Serie



**GEOMAX**

**Quick Guide**  
Version 1.0  
Deutsch

# 1 Wichtige Informationen über Ihr Instrument



Lesen und befolgen Sie die Gebrauchsanweisung auf dem beigefügten USB-Stick, bevor Sie das Produkt verwenden.



Sorgfältig aufbewahren!

## BestimmungsmäÙe Verwendung

- Messen von Horizontal- und Vertikalwinkeln.
- Messen von Distanzen.
- Visualisierung der Ziel- und Stehachse.

## Laserprodukte

Die Instrumente enthalten die folgenden Laserprodukte:

| Laserprodukt                             | Laserklasse |
|--|-------------|
| EDM (Elektronische Distanzmessung)-Modul |             |
| • Messungen mit Reflektoren              | Klasse 1    |
| • Messungen ohne Reflektoren*            | Klasse 3R   |
| Roter Laserpointer*                      | Klasse 3R   |
| Laserlot                                 | Klasse 2    |

\* optionales Laserprodukt

- Die Klassifikation des EDM, des roten Laserpointers und des Laserlots entspricht der Richtlinie IEC 60825-1 (2014-05).

 **VORSICHT****Laserprodukte der Klasse 3R**

Aus Sicherheitsgründen ist der direkte Blick in den Strahl von Klasse 3R Laserprodukten immer als gefährlich einzustufen.

**Gegenmaßnahmen:**

- ▶ 1. Blicken Sie nicht direkt in den Strahl.
  - 2. Richten Sie den Strahl nicht auf andere Personen.
- 

 **VORSICHT****Laserprodukte der Klasse 2**

Aus sicherheitstechnischer Sicht können Klasse 2 Laserprodukte grundsätzlich die Augen gefährden.

**Gegenmaßnahmen:**

- ▶ 1. Blicken Sie nicht in den Laserstrahl und betrachten Sie ihn nicht durch optische Instrumente.
  - 2. Richten Sie den Strahl nicht auf andere Personen oder Tiere.
-



## Austrittsstelle der Laserstrahlen

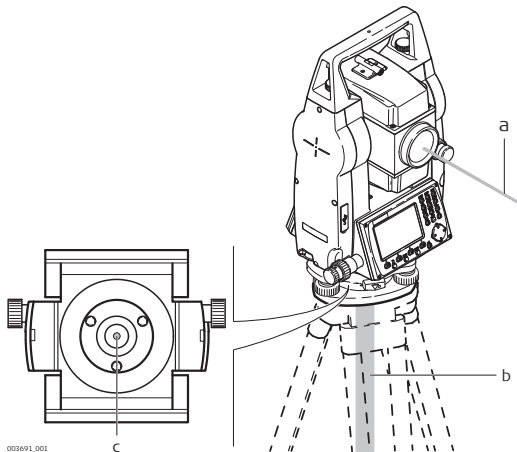

- a Laserstrahl (EDM)
- b Laserstrahl (Laserlot)
- c Ausgang für den Laserstrahl (Laserlot)



Das Produkt darf nicht im Hausmüll entsorgt werden.

---

### **Konformität mit nationalen Vorschriften**

- FCC Teil 15 (gültig in USA).
  - Hiermit erklärt GeoMax AG, dass die Funkausrüstung des Typs Zoom25/Zoom50 der Richtlinie 2014/53/EU und anderen anwendbaren Europäischen Richtlinien entspricht. Der vollständige Text der EU-Konformitätserklärung kann unter <http://www.geomax-positioning.com/Downloads.htm> eingesehen werden.
- CE** Geräte der Klasse 1 entsprechend der Europäischen Richtlinie 2014/53/EU (RED) können ohne Einschränkung in jedem Mitgliedsstaat des EWR in den Verkehr gebracht und in Betrieb genommen werden.
- In Ländern mit nationalen Vorschriften, die nicht durch die Europäische Richtlinie 2014/53/EU oder FCC Teil 15 abgedeckt sind, sind die Bestimmungen und Zulassungen für den Betrieb zu prüfen.

## Gefahrgutvorschriften

Die Produkte von GeoMax werden durch Lithiumakkus mit Energie versorgt.

DE

Lithiumakkus können unter bestimmten Voraussetzungen gefährlich werden und ein Sicherheitsrisiko darstellen. Unter bestimmten Voraussetzungen können Lithiumakkus überhitzen und sich entzünden.



Wenn Ihr GeoMax Produkt mit Lithiumakkus an Bord eines Verkehrsflugzeugs transportiert oder als Luftfracht versendet wird, muss dies in Übereinstimmung mit den **IATA Gefahrgutvorschriften** geschehen.



GeoMax hat **Richtlinien** bezüglich Transport und Versand von GeoMax Produkten mit Lithiumakkus erstellt. Wir bitten Sie, vor jedem Transport eines GeoMax Produkts die Richtlinien auf unserer Webseite (<http://www.geomax-positioning.com/dgr>) zu konsultieren, um sicherzugehen, dass die GeoMax Produkte entsprechend der IATA-Gefahrgutvorschriften korrekt transportiert werden.



Beschädigte oder defekte Akkus dürfen nicht an Bord eines Flugzeugs transportiert werden. Stellen Sie deshalb sicher, dass Ihre Akkus sicher transportiert werden können.

---

## 2 Komponenten des Produkts

### Instrumentenbestandteile Teil 1 von 2

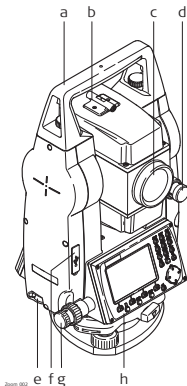

- a Abnehmbarer Tragegriff
- b Visierhilfe, zur groben Zieleinrichtung
- c Objektiv mit integriertem, elektrooptischem Distanzmesser (EDM). Austretender EDM Laserstrahl
- d Vertikaltrieb
- e Schnittstelle RS232/USB
- f USB-Schnittstelle
- g Seitentrieb
- h Zweite Tastatur\*

\* Optional

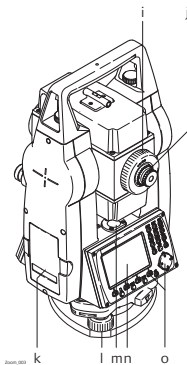
**Instrumentenbestandteile Teil 2  
von 2**

- i Fokussiertrieb
- j Okular
- k Batterie-Deckel
- l Fußschrauben
- m Dosenlibelle
- n Display
- o Tastatur

## Tastatur



Die Tastatur kann abhängig vom Modell des Instruments abweichen.

DE



- a Alphanumerischer Tastenblock
- b Navigationstaste
- c **ENTER**-Taste
- d Funktionstasten **F1** bis **F4**
- e **ESC**-Taste
- f **FNC**-Taste
- g **BLÄTTERN**-Taste

### 3 Technische Daten

---

#### Umweltspezifikationen

#### Temperatur

| Betriebstemperatur [°C] | Lagertemperatur [°C] |
|-------------------------|----------------------|
| -20 bis +50             | -40 bis +70          |

---

#### Schutz gegen Wasser, Staub und Sand

IP55 (IEC 60529)

#### Feuchtigkeit

Max. 95 % nicht kondensierend.

Den Auswirkungen von Kondensation sollte durch periodisches Austrocknen des Instrumentes entgegengewirkt werden.



## 4

# Wartung und Transport

---

### Wartung und Transport

- Transportieren Sie das Produkt in seinem Originalbehälter oder tragen Sie das Stativ mit aufgesetztem und angeschraubtem Produkt aufrecht zwischen den Stativbeinen über der Schulter, um das Produkt gegen Schläge und Vibrationen zu sichern.
  - Führen Sie periodisch Testmessungen durch und wenden Sie die in der Gebrauchsanweisung beschriebene Feldjustierung an, besonders nach einem Sturz, nach einer langen Lagerung oder nach einem Transport des Produkts.
-

# 5 Bedienung

## Ein- und Aus- schalten des Instruments

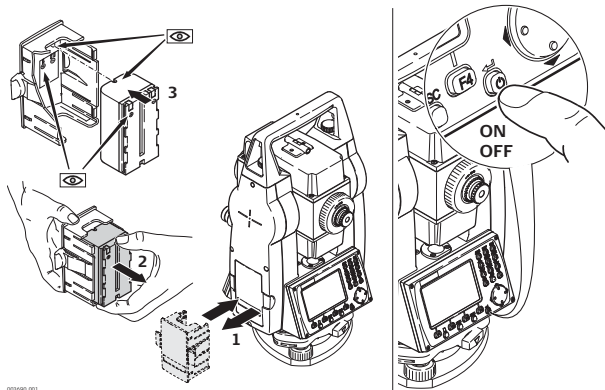

002690\_001



Die Batterie muss vor der Erstverwendung geladen werden.

---

DE



**866471-1.0.0de**

Originaltext (866471-1.0.0en)

© 2017 GeoMax AG, Widnau, Schweiz



**GeoMax AG**  
[www.geomax-positioning.com](http://www.geomax-positioning.com)

# GeoMax Zoom25/50 Series



**GE**  **MAX**

**Guía Rápida**  
Versión 1.0  
Español

# 1 Información importante de su instrumento

 Antes de utilizar el producto, lea y siga las instrucciones del manual del usuario que se encuentra en la memoria USB que se entrega.

 ¡Conservar para futuras consultas!

## Utilización

- Medición de ángulos horizontales y verticales.
- Medición de distancias.
- Visualización del eje de puntería y del eje vertical.

## Productos láser

Los instrumentos incluyen los siguientes productos láser:

| Producto láser                                  | Clase de láser |
|---|----------------|
| Módulo EDM (Medición electrónica de distancias) |                |
| • mediciones con prisma                         | Clase 1        |
| • mediciones sin prisma*                        | Clase 3R       |
| Puntero láser rojo*                             | Clase 3R       |
| Plomada láser                                   | Clase 2        |

\* producto láser opcional

- La clasificación para el EDM, el puntero láser rojo y la plomada láser cumple con la norma IEC 60825-1 (2014-05).

 **ATENCIÓN****Productos láser 3R**

Por razones de seguridad, los productos láser de clase 3R deben considerarse como potencialmente peligrosos.

**Medidas preventivas:**

- ▶ 1. Evitar observar directamente el rayo.
- 2. No dirigir el rayo a terceros.

 **ATENCIÓN****Productos de la clase de láser 2**

Los productos láser clase 2 se consideran peligrosos para la vista.

**Medidas preventivas:**

- ▶ 1. Evitar observar directamente el rayo o a través de instrumentos ópticos.
- 2. Evitar apuntar con el rayo a personas o animales.



## Ubicaciones de las aperturas de los láser

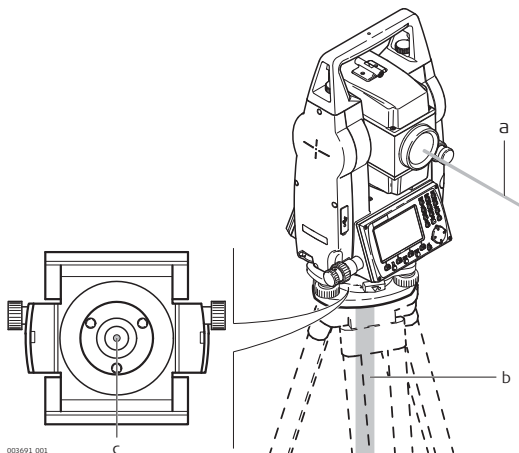

- a Rayo láser (EDM)
- b Rayo láser (plomada láser)
- c Salida del rayo láser (plomada láser)



No deseche el producto con la basura doméstica.

---

**Conformidad con regulaciones nacionales**

- FCC Parte 15 (válido en EE. UU.).
  - Por la presente, GeoMax AG declara que el equipo de radio modelo Zoom25/Zoom50 cumple la Directiva 2014/53/UE y otras Directivas comunitarias aplicables. El texto completo de la declaración de conformidad UE se puede consultar en <http://www.geomax-positioning.com/Downloads.htm>.
- CE** Un equipo de clase 1 según la Directiva comunitaria 2014/53/UE (RED) puede comercializarse y ponerse en servicio sin restricciones en cualquier estado miembro del EEE.
- La conformidad para países con otras regulaciones nacionales que no estén cubiertas por la FCC parte 15 o la Directiva comunitaria 2014/53/UE debe ser aprobada antes del uso y funcionamiento.

## Reglamentos de Mercancías Peligrosas

Los productos de GeoMax son alimentados por baterías de litio.

Las baterías de litio pueden ser peligrosos en ciertas condiciones y pueden representar un peligro para la seguridad. En ciertas condiciones, las baterías de litio pueden recalentarse y provocar un incendio.

ES



Al llevar o enviar el GeoMax producto con baterías de litio a bordo de un avión comercial, debe hacerlo de acuerdo con los **IATA Dangerous Goods Regulations**.



GeoMaxha desarrollado **Lineas guías** sobre "como transportarGeoMaxel producto" y "Como enviarGeoMaxel producto" con baterías de Litio Antes de cualquier transporte de un GeoMax producto, le pedimos que consulte estas guías en nuestra página web (<http://www.geomax-positioning.com/dgr>) para asegurarse de que se ajustan los IATA Dangerous Goods Regulations y que los GeoMax productos pueden ser transportados correctamente.



Baterías Dañadas o defectuosas están prohibidas de ser llevadas o transportadas a bordo de cualquier aeronave. Por lo tanto, asegúrese de que la condición de cualquier batería es segura para el transporte.

---

## 2 Componentes del instrumento

### Componentes del instrumento parte 1 de 2

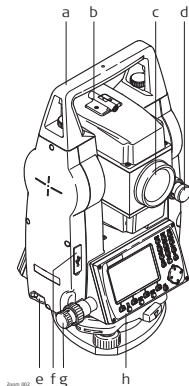

- a Asa desmontable
- b Objetivo óptico
- c Objetivo con distanciómetro electrónico (EDM) integrado. Orificio de salida del rayo EDM
- d Tornillo para movimiento vertical
- e Interfaz RS232/USB
- f Puerto para conexión USB de host
- g Tornillo para movimiento horizontal
- h Segundo teclado\*

\* Opcional

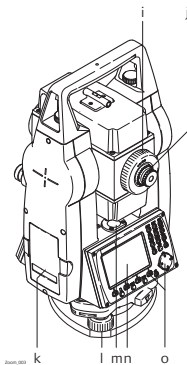
**Componentes del  
instrumento,  
parte 2 de 2**

- i Anteojos para enfocar imagen
- j Ocular; retícula para enfoque
- k Tapa de la batería
- l Tornillo nivelante
- m Nivel esférico
- n Pantalla
- o Teclado

## Teclado



El diseño del teclado puede cambiar, dependiendo del modelo del instrumento.



- a Teclado alfanumérico
- b Tecla de navegación
- c Tecla **ENTER**
- d Teclas de función **F1** a **F4**
- e Tecla **ESC**
- f Tecla **FNC**
- g Tecla **PAG**

### 3

## Datos técnicos

### Especificaciones ambientales

#### Temperatura

| Rango de temperaturas de operación [°C] | Rango de temperaturas de almacenamiento [°C] |
|---|--|
| -20 a +50                               | -40 a +70                                    |

#### Protección contra el agua, el polvo y la arena

IP55 (IEC 60529)

#### Humedad

Máx. 95 % sin condensación.

Los efectos de la condensación se pueden contrarrestar en forma efectiva secando periódicamente el instrumento.



## 4

# Cuidados y transporte

---

### Cuidados y transporte

- Lleve siempre el producto en su maletín original, o en el trípode al hombro con las patas abiertas, para proteger al producto contra golpes y vibraciones.
  - Efectúe periódicamente mediciones de control y ejecute los ajustes de campo indicados en el Manual de empleo, principalmente si el producto ha sufrido una caída o después de largos periodos de almacenamiento o transporte.
- 

ES

# 5 Funcionamiento

**Puesta en marcha y apagado del instrumento**

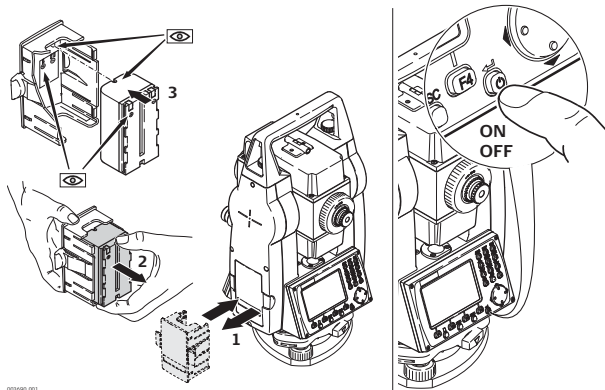

002690\_001



Cargue la batería antes de usarla por primera vez.

---



## **866471-1.0.0es**

Traducción de la versión original (866471-1.0.0en)

© 2017 GeoMax AG, Widnau, Switzerland



**GeoMax AG**  
[www.geomax-positioning.com](http://www.geomax-positioning.com)

# Série GeoMax Zoom25/50



**GE**  **MAX**

**Guide abrégé**  
Version 1.0  
Français

# 1 Informations importantes sur l'instrument



Avant l'emploi du produit, lire et respecter le manuel de l'utilisateur chargé sur la clé USB fournie.



A conserver pour une consultation ultérieure !

## Utilisation pré- vue

- Mesure d'angles horizontaux et verticaux.
- Mesure de distances.
- Visualisation de l'axe de visée et de l'axe vertical.

## Produits laser

Les instruments contiennent les produits laser suivants :

| Produit laser                                | Classe laser |
|--|--------------|
| Module EDM (mesure électronique de distance) |              |

| <b>Produit laser</b>        | <b>Classe laser</b> |
|-----------------------------|---------------------|
| • Mesures avec réflecteurs  | Classe 1            |
| • Mesures sans réflecteurs* | Classe 3R           |
| Pointeur laser rouge*       | Classe 3R           |
| Plomb laser                 | Classe 2            |

\*produit laser en option

- La classification pour l'EDM, le pointeur laser rouge et le plomb laser est conforme à CEI 60825-1 (2014-05).

 **ATTENTION****Produits laser 3R**

Du point de vue de la sécurité, il convient de traiter les produits laser de classe 3R comme potentiellement dangereux.

**Mesures préventives :**

- ▶ 1. Éviter une exposition oculaire directe au faisceau.
  - 2. Ne pas pointer le faisceau sur d'autres personnes.
- 

 **ATTENTION****Produits laser de classe 2**

Du point de vue de la sécurité, les produits laser de classe 2 ne sont pas totalement inoffensifs pour les yeux.

**Mesures préventives :**

- ▶ 1. Éviter de regarder les faisceaux laser de façon directe ou par le biais d'instruments optiques.
  - 2. Ne pas pointer le faisceau sur d'autres personnes ou sur des animaux.
-



## Emplacement des ouvertures laser

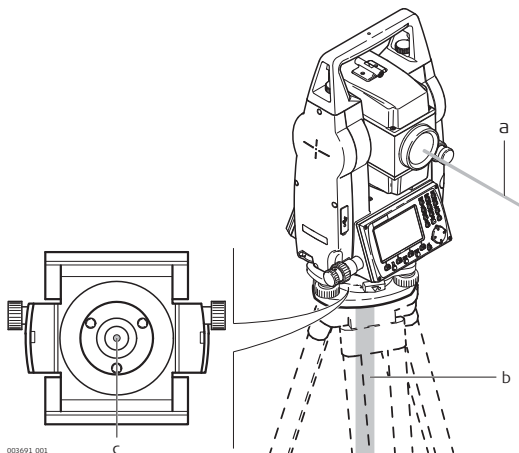

FR

- a Faisceau laser (EDM)
- b Faisceau laser (plomb laser)
- c Orifice de sortie du faisceau laser (plomb laser)



Ne jetez pas ce produit avec les ordures ménagères.

---

**Conformité avec  
les prescriptions  
nationales**

- FCC partie 15 (applicable aux Etats-Unis).
- GeoMax AG, déclare par la présente que l'équipement radio de type Zoom25/Zoom50 est conforme à la directive européenne 2014/53/UE et aux autres directives européennes applicables. Le texte complet de la déclaration UE de conformité peut être consulté à l'adresse <http://www.geomax-positioning.com/Downloads.htm>.



Équipement de classe 1 selon la directive européenne 2014/53/UE (RED) pouvant être commercialisé et mis en service sans aucune restriction dans tout pays membre de l'EEE.

- La conformité pour des pays dont la réglementation nationale n'est couverte ni par les règles FCC partie 15 ni par la directive européenne 2014/53/UE est à faire approuver préalablement à toute utilisation.

---

### **Dispositions sur les matières dangereuses**

Les produits de GeoMax sont alimentés par des batteries au lithium.

Les batteries au lithium peuvent être dangereuses dans certaines conditions et présenter un risque de sécurité. Dans certaines conditions, les batteries au lithium peuvent surchauffer et s'enflammer.



Lors du transport ou de l'expédition du produit GeoMax avec des batteries au lithium à bord d'un avion civil, il faut également respecter les dispositions IATA sur les matières dangereuses.



GeoMax a établi des consignes pour le transport des produits GeoMax et l'expédition de produits GeoMax avec des batteries au lithium. Avant de transporter un produit GeoMax <http://www.geomax-positioning.com/dgr>, il convient de consulter ces consignes sur le site Internet afin de veiller au respect des dispositions IATA sur les matières dangereuses et au transport correct des produits GeoMax.



Le transport ou l'expédition de batteries endommagées ou défectueuses est interdit. Il faut donc s'assurer de la sécurité de transport de toute batterie.

---

## 2

# Éléments d'instrument

### Composants de l'instrument, 1ère partie

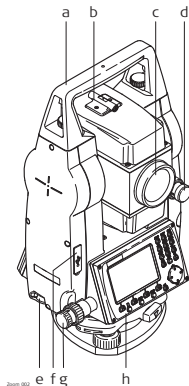

- a Poignée de transport amovible
- b Viseur
- c Objectif avec module de mesure de distance électronique (EDM). Sortie du faisceau laser EDM
- d Commande verticale
- e Interface RS232/USB
- f Port d'hôte USB
- g Commande horizontale
- h Deuxième clavier\*

\* En option

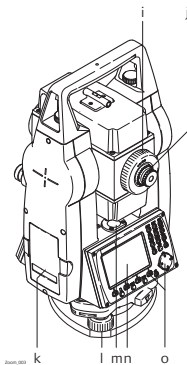
**Composants de  
l'instrument,  
2ème partie**

- i Mise au point de l'image de la lunette
- j Oculaire ; réticule de mise au point
- k Couverture du compartiment de batterie
- l Vis calante
- m Nivelles sphérique
- n Affichage
- o Clavier

## Clavier



La configuration du clavier varie en fonction du modèle d'instrument.



- a Clavier alphanumérique
- b Touche de navigation
- c Touche **ENTER**
- d Touches de fonction **F1** à **F4**
- e Touche **ESC**
- f Touche **FNC**
- g Touche **PAGE**

FR

### 3

## Caractéristiques techniques

### Environnement

### Température

| Température d'utilisation [°C] | Température de stockage [°C] |
|--------------------------------|------------------------------|
| De -20 à +50                   | De -40 à +70                 |

### Protection contre l'eau, la poussière et le sable

IP55 (CEI 60529)

### Humidité

95 % au maximum, sans condensation

Il convient de neutraliser les effets de la condensation par un séchage complet périodique de l'instrument.



## 4

# Entretien et transport

---

### Entretien et transport

- Transportez le produit dans son coffret d'origine ou portez le trépied, jambes écartées, sur l'épaule pour protéger le produit contre les chocs et vibrations.
  - Exécutez des mesures de contrôle périodiques et réalisez les ajustements terrain indiqués dans le manuel d'utilisation, notamment après un léger choc, un stockage de longue durée ou un transport mouvementé de l'instrument.
-

# 5 Utilisation

Mise sous et hors tension de l'instrument

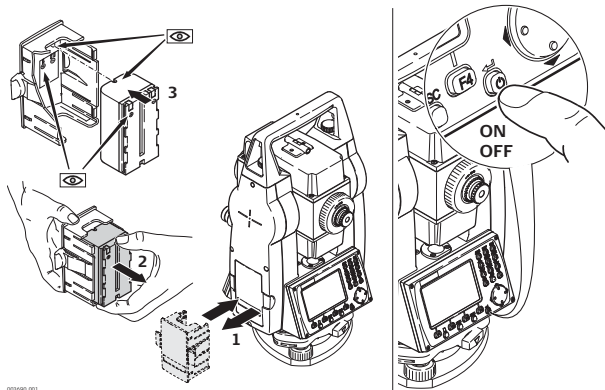

002690\_001



Veillez à charger la batterie avant la première utilisation.

---



## **866471-1.0.0fr**

Traduction de la version originale (866471-1.0.0en)

© 2017 GeoMax AG, Widnau, Suisse



**GeoMax AG**  
[www.geomax-positioning.com](http://www.geomax-positioning.com)

# Serie GeoMax Zoom25/50



**GE**  **MAX**

**Guida rapida**  
Versione 1.0  
Italiano

# 1

## Importanti informazioni sullo strumento

---



Prima di utilizzare il prodotto, leggere e seguire le indicazioni del Manuale d'uso contenuto nell'unità USB in dotazione.

---



Da conservare per futura consultazione.

---

### Uso previsto

- Misurazione di angoli orizzontali e verticali.
  - Misurazione di distanze.
  - Visualizzazione della direzione di puntamento e dell'asse verticale.
- 

### Prodotti laser

Lo strumento contiene i seguenti prodotti laser:

| <b>Prodotto laser</b>   | <b>Classe laser</b> |
|---|---------------------|
| Modulo EDM (Electronic Distance Measurement, Misura elettronica della distanza) |                     |
| • Misure con riflettori   | Classe 1            |
| • Misure senza riflettori*  | Classe 3R           |
| Puntatore laser rosso*  | Classe 3R           |
| Piombo laser  | Classe 2            |

IT

\*Prodotto laser opzionale

- La classificazione dell'EDM del puntatore laser rosso, e del piombo laser è conforme alla normativa IEC 60825-1 (2014-05).

 **ATTENZIONE****Prodotti laser 3R**

Dal punto di vista della sicurezza, i prodotti laser di classe 3R devono essere considerati potenzialmente pericolosi.

**Precauzioni:**

- ▶ 1. Evitare l'esposizione diretta degli occhi al raggio.
  - 2. Non puntare il raggio verso le persone.
- 

 **ATTENZIONE****Prodotti laser di classe 2**

Dal punto di vista della sicurezza, i prodotti laser di classe 2 non sono intrinsecamente sicuri per gli occhi.

**Precauzioni:**

- ▶ 1. Evitare di fissare il raggio o di guardarlo attraverso lo strumento.
  - 2. Non puntare il raggio verso persone o animali.
-



## Posizione delle aperture laser

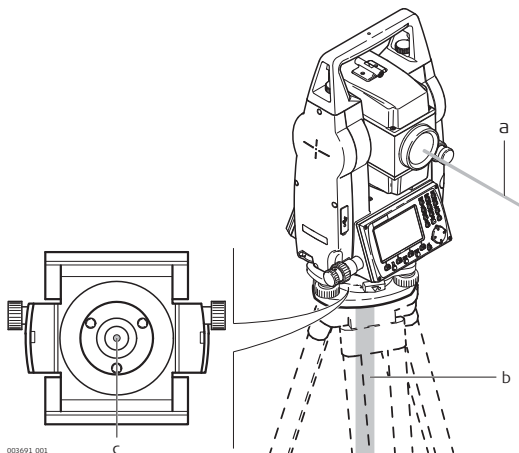

- a Raggio laser (EDM)
- b Raggio laser (piombo laser)
- c Uscita del raggio laser (piombo laser)

IT



Il prodotto non deve essere smaltito insieme ai rifiuti domestici.

---

**Conformità alla  
legislazione  
nazionale**

- FCC parte 15 (in vigore negli Stati Uniti).
  - SiGeoMax AG dichiara che l'apparecchiatura radio di tipo Zoom25/Zoom50 è conforme alla direttiva 2014/53/UE e alle altre direttive europee in vigore. Il testo completo della dichiarazione di conformità per l'UE è disponibile all'indirizzo <http://www.geomax-positioning.com/Downloads.htm>.
- CE** Gli strumenti di Classe 1 ai sensi della direttiva europea 2014/53/UE (RED) possono essere commercializzati e utilizzati senza limitazioni in qualsiasi stato membro del SEE.
- La conformità per i paesi in cui vigono altre disposizioni nazionali non coperte dalla direttiva FCC, parte 15, o dalla direttiva europea 2014/53/UE deve essere approvata prima della messa in esercizio.

## Regolazione Beni Pericolosi

I prodotti GeoMax sono alimentati con batterie al Litio.

Le batterie al litio possono essere pericolose in determinate condizioni e possono rappresentare un pericolo per la sicurezza. In determinate condizioni, le batterie al litio possono surriscaldarsi e prendere fuoco.



Quando si trasporta o spedire il prodotto GeoMax con batterie al litio a bordo di un aereo commerciale, è necessario farlo in conformità con le IATA Dangerous Goods Regulations.



GeoMax ha sviluppato Linee guida su "Come portare prodotti GeoMax" e "Come spedire prodotti GeoMax" con batterie al litio. Prima di ogni trasporto di un prodotto GeoMax, vi chiediamo di consultare queste linee guida sulla nostra pagina web (<http://www.geomax-positioning.com/dgr>) per garantire che siano in conformità con le IATA Dangerous Goods Regulations e che i prodotti GeoMax siano trasportati correttamente.



Su qualsiasi aereomobile è vietato il trasporto di batterie danneggiate o difettose. Pertanto, assicurarsi che la condizione di ogni batteria sia sicura per il trasporto.

## 2 Componenti dello strumento

### Componenti dello strumento - Parte 1 di 2

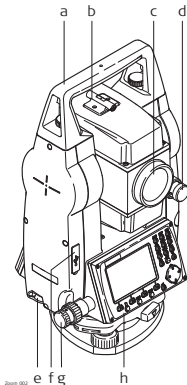

- a Maniglia di trasporto staccabile
- b Mirino ottico
- c Obiettivo con funzione di misurazione elettronica della distanza (Electronic Distance Measurement, EDM) integrata. Uscita raggio laser EDM
- d Vite micrometrica zenitale
- e Interfaccia RS232/USB
- f Porta USB host
- g Vite micrometrica azimutale
- h Seconda tastiera\*

\* Opzionale

## Componenti dello strumento - Parte 2 di 2

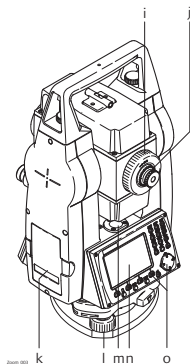

- i Ghiera di messa a fuoco immagine del  
cannocchiale
- j Oculare; reticolo di messa a fuoco
- k Coperchio batteria
- l Vite calante
- m Livella sferica
- n Display
- o Tastiera

**Tastiera**

Il layout della tastiera può variare a seconda del modello di strumento.



- a Tastierino alfanumerico
- b Tasto di navigazione
- c Tasto **ENTER**
- d Tasti funzione da **F1aF4**
- e Tasto **ESC**
- f Tasto **FNC**
- g Tasto **PAGINA**

### 3

#### Specifiche ambientali

## Dati tecnici

### Temperatura

| Temperatura d'esercizio [°C] | Temperatura di stoccaggio [°C] |
|------------------------------|--------------------------------|
| da -20 a +50                 | da -40 a +70                   |

IT

### Protezione dall'acqua, dalla polvere e dalla sabbia

IP55 (IEC 60529)

### Umidità

Max 95 % senza formazione di condensa.

Gli effetti della condensa si possono contrastare in modo efficace asciugando periodicamente lo strumento.

## 4

### Cura e trasporto

---

#### Manutenzione e trasporto

- Trasportare il prodotto nell'imballo originale o trasportare il treppiede ad aste aperte, appoggiandolo sulla spalla in modo da proteggere lo strumento da urti e vibrazioni.
  - Eseguire periodicamente le misure di controllo e le regolazioni indicate nel manuale d'uso, in particolare se il prodotto è caduto o è stato immagazzinato per lungo tempo o trasportato.
-



# 5

## Funzionamento

Accensione e spegnimento dello strumento

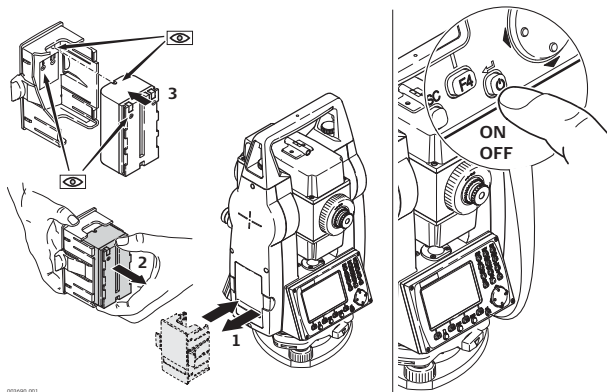

002690\_001

IT



Caricare la batteria prima di utilizzarla per la prima volta.

---





## **866471-1.0.0it**

Traduzione dal testo originale (866471-1.0.0en)

© 2017 GeoMax AG, Widnau, Switzerland



**GeoMax AG**  
[www.geomax-positioning.com](http://www.geomax-positioning.com)

# Série GeoMax Zoom25/50



**GE**  **MAX**

**Guia Rápido**  
Versão 1.0  
Português - Brasil

# 1 Informações importantes sobre o instrumento

---



Leia e siga o Manual do Usuário gravado no Pendrive antes de usar o produto.

---



Manter para referência futura!

---

## **Pretenção de uso**

- Medições dos ângulos horizontal e vertical.
  - Medições de distâncias.
  - Visualização da direção da mira e eixo vertical.
- 

## **Produtos laser**

O instrumento contém os seguintes produtos laser:

| <b>Produto laser</b>                         | <b>Classe do laser</b> |
|--|------------------------|
| Módulo EDM (Medição Eletrônica de Distância) |                        |
| • medições com refletores                    | Classe 1               |
| • medições sem refletores*                   | Classe 3R              |
| Apontador de laser vermelho*                 | Classe 3R              |
| Prumo laser                                  | Classe 2               |

\* produto laser opcional

- A classificação para o EDM, mira laser vermelho está de acordo com IEC 60825-1 (2014-05).

 **CUIDADO****Produtos de laser 3R**

Na perspectiva de segurança, o laser de classe 3R, deve ser tratado como potencialmente perigoso.

**Precauções:**

- ▶ 1. Previna da exposição direta do olho ao raio
  - 2. Não aponte o raio para outras pessoas.
- 

 **CUIDADO****Produtos de laser Classe 2**

A partir de uma perspectiva de segurança, os lasers classe 2 não são inerentemente seguros para os olhos.

**Precauções:**

- ▶ 1. Evite olhar para o raio ou visualizá-lo através de instrumentos óticos.
  - 2. Evite apontar o raio para pessoas ou animais.
-



## Localização das aberturas laser

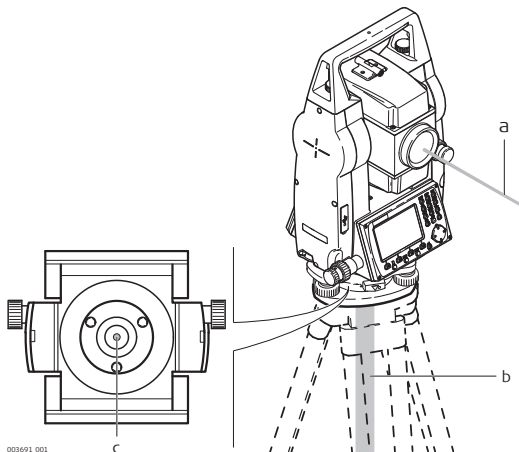

- a Raio laser (EDM)
- b Raio laser (Prumo laser)
- c Saída do raio laser (Prumo laser)



O produto não deve ser descartado juntamente com o lixo doméstico.

---

**Conformidade  
com regulamen-  
tos nacionais**

- FCC Parte 15 (aplicável nos EUA).
  - Pelo presente, a GeoMax AG, declara que o equipamento de rádio tipo Zoom25/Zoom50 está em conformidade com a Diretiva 2014/53/UE e outras Diretivas europeias pertinentes. O texto completo da declaração de conformidade pode ser consultado em <http://www.geomax-positioning.com/Downloads.htm>.
- CE** O Equipamento de Classe 1 de acordo com a Diretiva Europeia 2014/53/CE (RED) pode ser colocado no mercado e também colocado em serviço sem restrições em qualquer Estado membro do EEA.
- A conformidade para países com outras regulações nacionais não cobertas pela FCC part 15 ou pela diretiva Europeia 2014/53/CE deve ser aprovada antes do uso e operação.

## Regulamentos de Produtos Perigosos

O produto GeoMax é alimentado por baterias de Lítio.

As baterias de Lítio podem ser perigosas em determinadas condições e podem representar um risco de segurança. Em determinadas condições, as baterias de Lítio podem superaquecer e pegar fogo.



Ao carregar ou despachar o seu produto GeoMax com bateria de Lítio a bordo de um avião comercial, você deve fazê-lo de acordo com os **Regulamentações Sobre Mercadorias Perigosas IATA**.



A GeoMax desenvolveu **Guias** de "Como carregar produtos GeoMax" e "Como despachar produtos GeoMax" com baterias de Lítio. Antes de qualquer transporte de um produto GeoMax, nós pedimos a você que consulte estas Guias na nossa página web (<http://www.geomax-positioning.com/dgr>) para ter certeza de que você cumpre com as Regulamentações Sobre Produtos Perigosos IATA e que o produto GeoMax pode ser transportado corretamente.

PT-BR



Baterias defeituosas ou danificadas são proibidas de serem transportadas a bordo de qualquer aeronave. Portanto, tenha a certeza de que as condições de qualquer bateria estão seguras para transporte.

---

## 2 Componentes do instrumento

### Componentes do instrumento parte 1 de 2

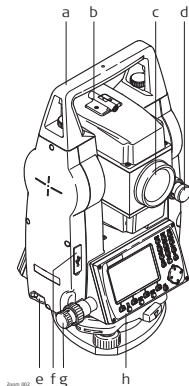

- a Alça destacável
- b Mira
- c Objetiva com o EDM integrado Saída do raio laser EDM
- d Comando vertical
- e Interface RS232/USB
- f Porta USB
- g Comando horizontal
- h Segundo teclado\*

\* Opcional

PT-BR

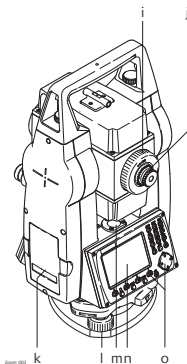
**Componentes do  
instrumento  
parte 2 de 2**

- i Focagem da imagem
- j Ocular; focagem do retículo
- k Tampa da bateria
- l Parafuso calante
- m Nível circular
- n Tela
- o Teclado

## Teclado



A disposição das teclas pode variar conforme o modelo do instrumento.



- a Teclado alfanumérico
- b Tecla de navegação
- c Tecla **ENTER**
- d Tecla de função **F1aF4**
- e Tecla **ESC**
- f Tecla **FNC**
- g Tecla **PÁGINA**

PT-BR

### 3

## Dados técnicos

### Especificações ambientais

#### Temperatura

| Temperatura de operação [°C] | Temperatura de armazenamento [°C] |
|------------------------------|-----------------------------------|
| -20 a +50                    | -40 a +70                         |

#### Proteção contra água, poeira e areia

IP55 (IEC 60529)

#### Umidade

Max 95 % não condensável.

Os efeitos da condensação são eficazmente neutralizados através de secagem periódica do instrumento.



## 4

# Cuidados e Transporte

---

### **Cuidados e transporte**

- Transportar o instrumento no estojo de transporte original ou transportar com o tripé, desde que, com as pernas abertas sobre o ombro, a proteger o equipamento contra os choques e vibrações.
  - Efetuar regularmente medições de ensaio e os ajustamentos de campo indicados no Manual de Utilização, particularmente depois de queda do instrumento, transporte ou armazenamento durante longos períodos de tempo.
- 

PT-BR

## 5 Operação

Ligando e desligando o instrumento

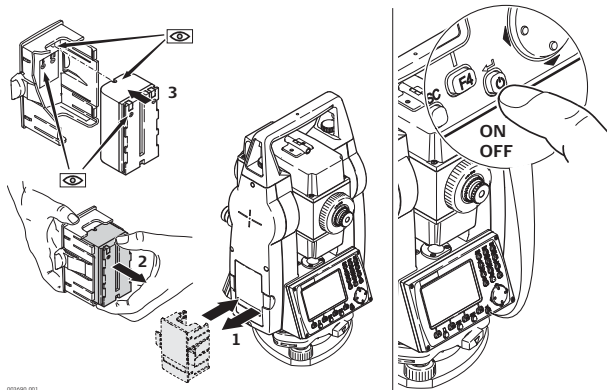

002690\_001



A bateria deve ser carregada antes de utilizá-la pela primeira vez.

---



## **866471-1.0.0pt-br**

Traduzido do texto original (866471-1.0.0en)

© 2017 GeoMax AG, Widnau, Suíça



**GeoMax AG**  
[www.geomax-positioning.com](http://www.geomax-positioning.com)

# GeoMax Zoom25/50



**Краткое руководство**

Версия 1.0

Русский

# 1

## Важная информация о Вашем Инструменте



Перед использованием инструмента ознакомьтесь с руководством пользователя с прилагаемого USB-накопителя.



Сохраняйте документацию для использования в дальнейшем в качестве справочника!

### Допустимое использование

- Измерение горизонтальных и вертикальных углов
- Измерение расстояний.
- Визуализация направления визирования и положения оси вращения тахеометра

### Лазерные устройства

Измерительный прибор содержит следующие лазерные устройства:

| Лазерное устройство   | Класс лазера |
|---|--------------|
| EDM (Electronic Distance Measurement) модуль лазерного дальномера |              |
| • измерения на отражатель   | Класс 1      |
| • безотражательный режим*   | Класс 3R     |
| Видимый красный лазерный указатель*                               | Класс 3R     |
| Лазерный отвес  | Класс 2      |

RU

\* дополнительное лазерное устройство

- Классификация EDM, Лазерного целеуказателя и Лазерного отвеса приведена в соответствии с IEC 60825-1 (2014-05).

 **ОСТОРОЖНО****Лазерные устройства 3R**

С точки зрения безопасности лазерные устройства класса 3R должны рассматриваться как потенциально опасные

**Меры предосторожности:**

- ▶ 1. Избегайте прямого попадания луча в глаза
- ▶ 2. Не направляйте лазерный пучок на других людей.

 **ОСТОРОЖНО****Лазерные устройства класса 2**

С точки зрения эксплуатационных рисков лазерные приборы класса 2 не представляют собой опасности для глаз.

**Меры предосторожности:**

- ▶ 1. Старайтесь не смотреть на луч невооруженным глазом и через оптические устройства
- ▶ 2. Не направляйте луч на людей или животных.



## Расположение апертур лазеров

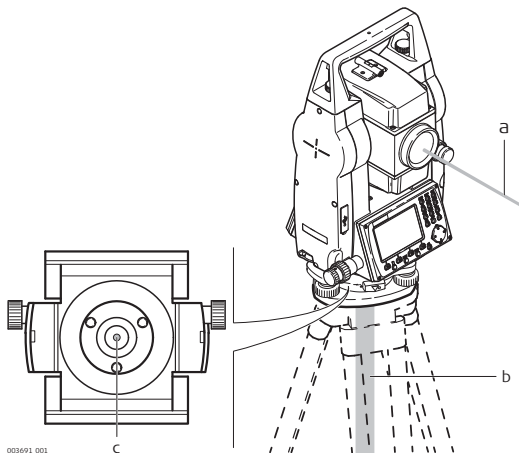

- a Лазерный луч (EDM)
- b Лазерный луч (Лазерный отвес)
- c Выход для лазерного луча (Лазерный отвес)

RU



Продукт не должен утилизироваться вместе с бытовыми отходами.

### Соответствие национальным нормам

- FCC, Часть 15 (применимы в США).
- Настоящим GeoMax AG заявляет, что данный тип радиооборудования Zoom25/Zoom50 соответствует положениям Директивы 2014/53/ЕС и других применимых Директив ЕС. С полным текстом декларации ЕС о соответствии можно ознакомиться на сайте <http://www.geomax-positioning.com/Downloads.htm>.



Оборудование класса 1 согласно Директиве 2014/53/ЕС на радиооборудование (RED) может выпускаться на рынок и использоваться без каких-либо ограничений во всех странах ЕЭЗ.

- Соответствие нормам других стран отличающимся от указанных в части 15 норм FCC или Европейской директивы 2014/53/ЕС, должно быть обеспечено до начала эксплуатации.

## Правила по опасным материалам

Питание оборудования GeoMax осуществляется литиевыми батареями.

Литиевые батареи в некоторых условиях могут представлять опасность. В определенных условиях, литиевые батареи могут нагреваться и воспламеняться.



Перевозка товаров GeoMax, питающихся от литиевых батарей, средствами авиации, должна осуществляться согласно **Правилам IATA по опасным материалам**.



GeoMax разработала **Руководство** по перевозке продуктов GeoMax и перемещению продуктов GeoMax с литиевыми батареями. Перед транспортировкой оборудования GeoMax, прочитайте руководство по перевозке на сайте (<http://www.geomax-positioning.com/dgr>) и убедитесь, что не нарушаете Правила IATA по опасным материалам а также что транспортировка оборудования GeoMax организована правильно.



Поврежденные или дефектные батареи запрещены к перевозке на любом авиатранспортном средстве. Перед перевозкой удостоверьтесь в качестве транспортируемых батарей.

RU

## 2 Компоненты MC80

Компоненты прибора, часть 1 из 2

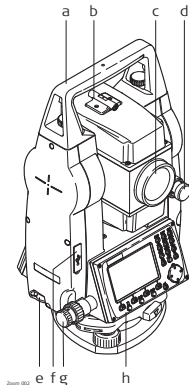

- a Съемная транспортировочная ручка
- b Оптический визир
- c Объектив со встроенным дальномером (EDM). Выход лазерного луча (EDM)
- d Наводящий винт вертикального круга
- e Коммуникационные разъемы RS232/USB
- f Порт USB
- g Наводящий винт горизонтального круга
- h Вторая клавиатура\*

\* Дополнительно

## Компоненты прибора, часть 2 из 2

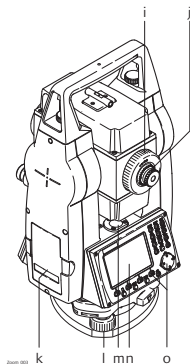

- i Фокусировочное кольцо объектива
- j Окуляр; ориентация сетки
- k Крышка аккумуляторного отсека
- l Подъемный винт
- m Круглый уровень
- n Экран
- o Клавиатура

RU

Клавиатура



Раскладка клавиатуры может отличаться в зависимости от модели.



- a Алфавитно-цифровая панель
- b Навигационная клавиша
- c Кнопка ENTER (Ввод)
- d Функциональные клавиши **F1 - F4**
- e Кнопка **ESC**
- f Кнопка **FNC**
- g Кнопка **PAGE**

### 3

## Технические характеристики

### Эксплуатационные характеристики

#### Температура

| Рабочая температура [ЖС] | Температура хранения [ЖС] |
|--------------------------|---------------------------|
| от -20 до +50            | от -40 до +70             |

#### Защита от влаги, пыли и песка

IP55 (IEC 60529)

#### Влажность

Максимум 95 % без конденсации

Влияние конденсации влаги успешно устраняется периодической протиркой и просушкой инструмента

RU

## 4 **Транспортировка и хранение**

---

### **Транспортировка в ходе полевых работ**

- При переноске инструмента в ходе полевых работ обязательно убедитесь в том что он переносится в собственном контейнере либо на штативе в вертикальном положении с целью защиты инструмента от ударов и вибраций.
  - Периодически проводите проверки и юстировки инструмента в поле описанные в Руководстве пользователя, особенно после того, как прибор роняли, не использовали в течение длительного времени или перевозили.
-



## 5

## Работа с инструментом

Включение и  
выключение при-  
бора

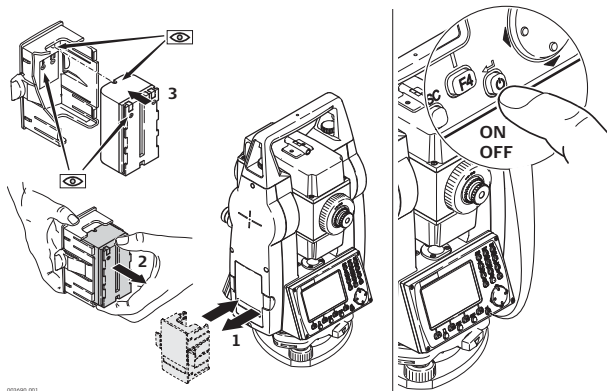

RU



Батарея должна быть заряжена перед первым использованием инструмента

---





**866471-1.0.0ru**

Перевод исходного текста (866471-1.0.0en)

© 2017 GeoMax AG, Виднау, Швейцария



**GeoMax AG**  
[www.geomax-positioning.com](http://www.geomax-positioning.com)





## **866471-1.0.0multilingual**

Original text (866471-1.0.0en)

© 2017 GeoMax AG, Widnau, Switzerland



**GeoMax AG**

[www.geomax-positioning.com](http://www.geomax-positioning.com)